

CONCRETE HAND CRUNCHER



Powered by three phase electricity, heavy jobs can be effortlessly handled for both internal and external structures.

CONCRETE HAND CRUNCHER

The Concrete Hand Cruncher can crush concrete up to 300mm thick and is virtually silent.

Operated by a two-man team, the G clamp (as shown) is placed over the material to be crushed.



The operator then activates the hydraulic ram which in turn crushes the material with no vibration and minimal noise.

For those jobs where noise or vibration is a problem - for example shopping centres or hospitals - our hand cruncher is the silent, more controlled answer to conventional electric or air hammers.

TECHNICAL DATA - Concrete Crushing System Type BZ

CRUSHER TYPES BZ

- ◆ Super light construction of special aircraft alloy for easy handling
- ◆ A quick change of the screw points opens the way to easy demolition of small walls and stairs
- ◆ Required power packs:
Type BW-2, electric motor
Type BW-2B, gasoline motor
- ◆ Weight: 47 kg, 104 lbs

CRUSHING PERFORMANCE

- ◆ Wall thickness 120 - 300 mm
- ◆ Crushing power 30 t

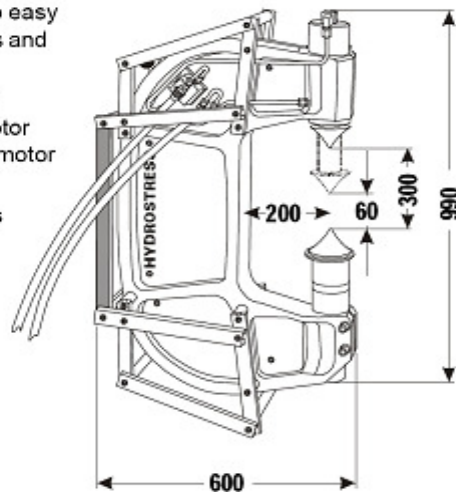

OPTIONS

- ◆ Steel point BZ
- ◆ Extractor for steel point BZ
- ◆ Distance washers: 25 and 50 mm
- ◆ Leather apron
- ◆ Helmet with protective mask
- ◆ Protective goggles
- ◆ Transport trolley to BZ



Crusher type BZ

